

'C' DIMENSION CONTROLS CORK FIT AND MUST BE MAINTAINED FROM 3.2 mm TO 15.9 mm DOWN FROM TOP OF FINISH.

'I' DIM = 17.5 mm MIN

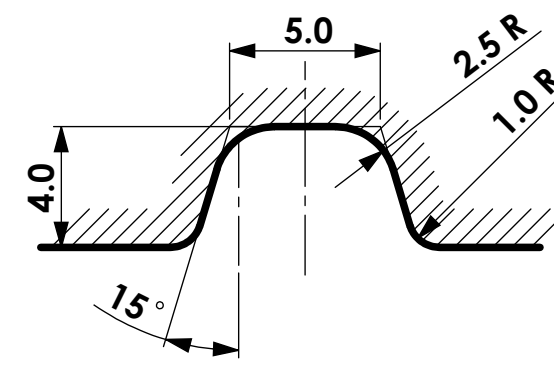

SECTION 'X'-'X'
SCALE 4:1

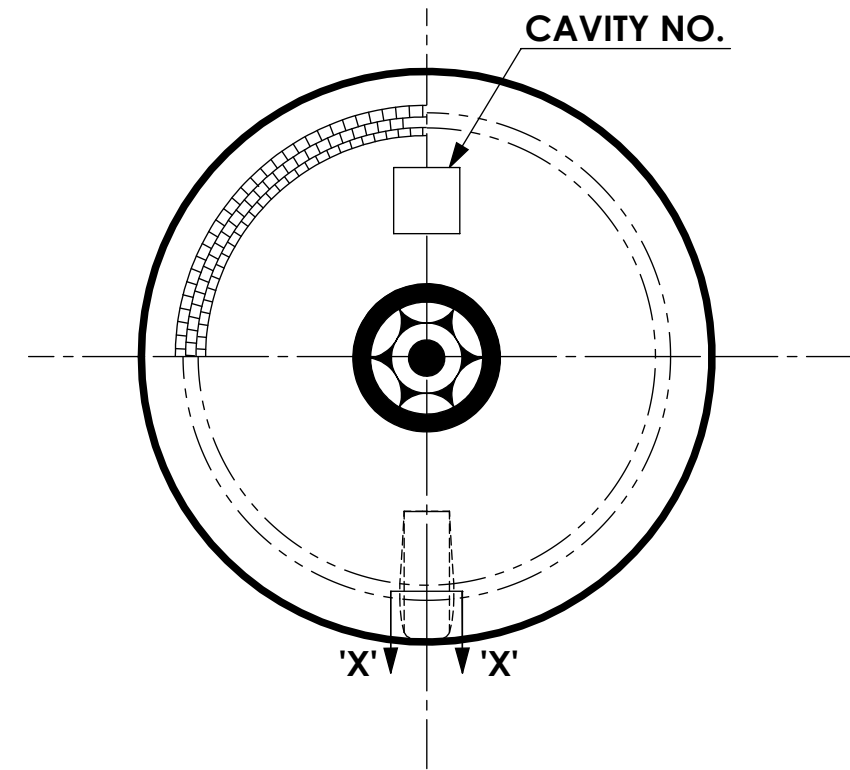
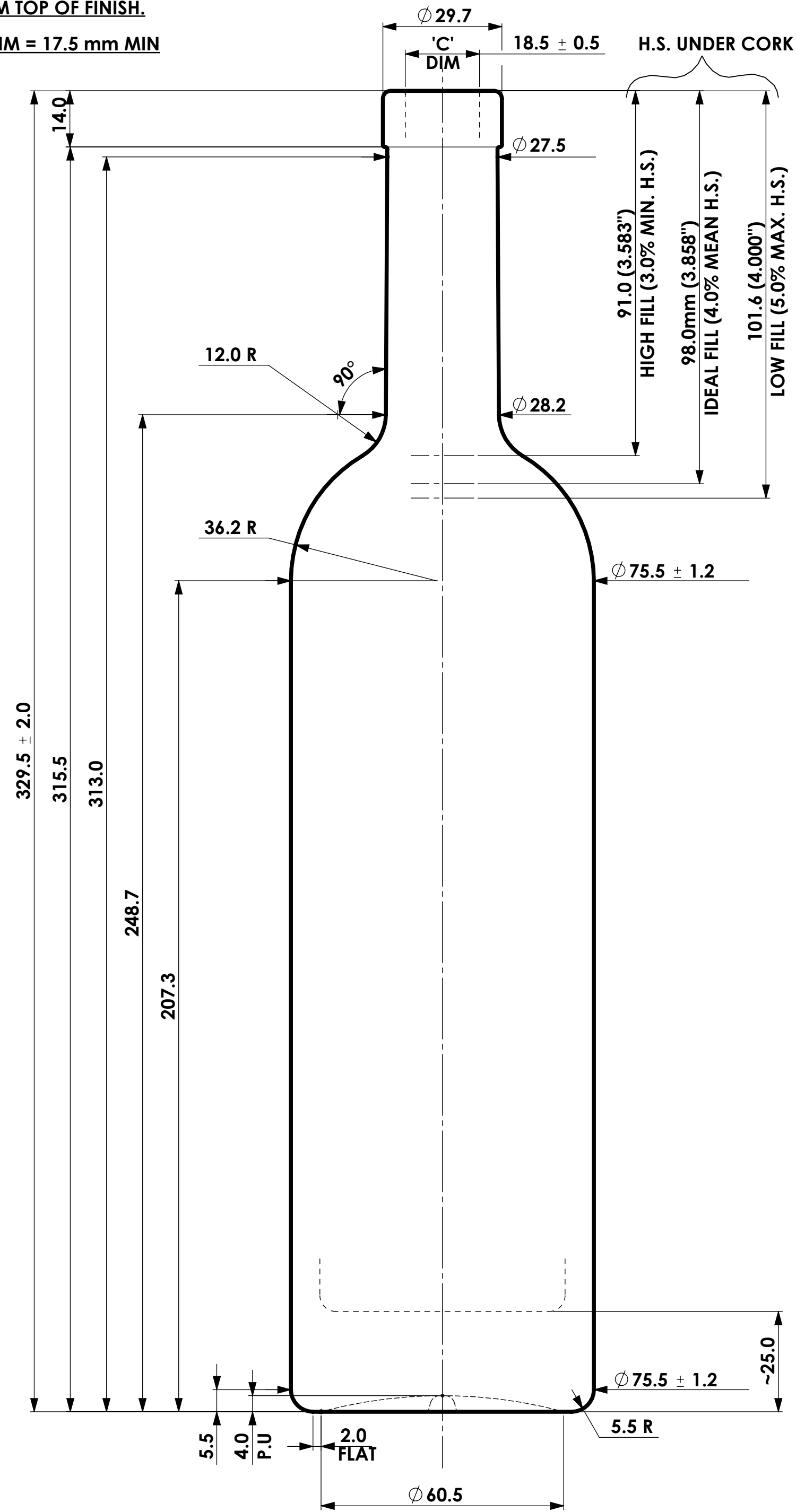
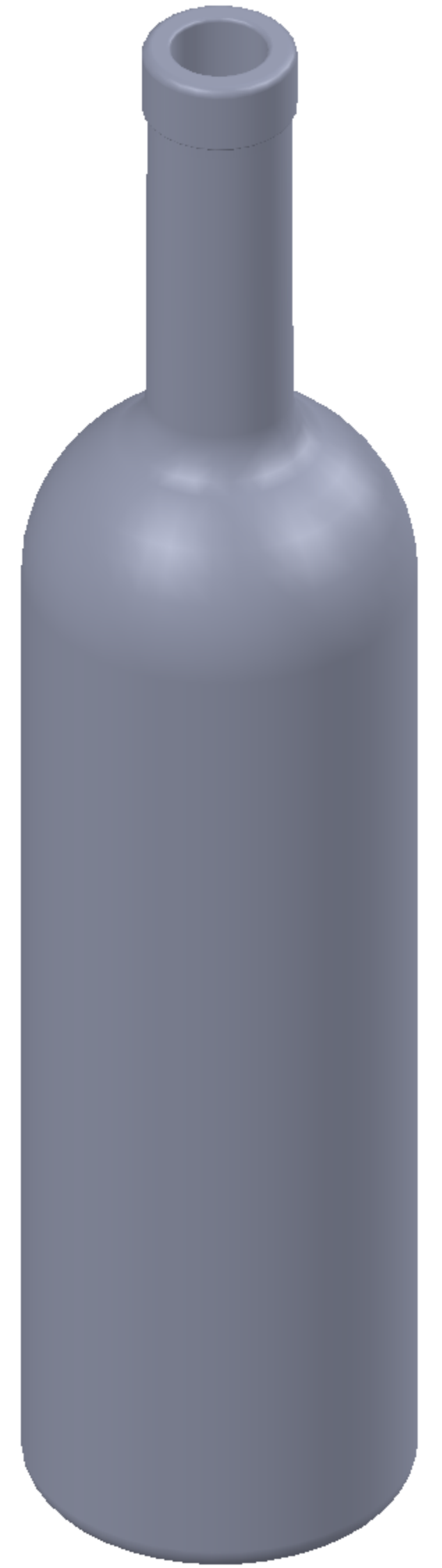

Liquor Bottle

305 Madison Ave., Suite 1357, New York, NY 10165 Tel (212)922-2813; Fax (212) 922-2826

DESCRIPTION	
750 ML HOLLY 1	
O'FLOW CAP	785.0 ml ± 7.4 (26.54 FL.OZ. ± 0.25)
WEIGHT	750.0 g ± 28.0 (26.46 OZ. ± 1.00)
FINISH	CORK
IDEAL FILLPOINT	750.0 ml(25.36 FL.OZ.) @ 98.0mm
LOW FILLPOINT	
HIGH FILLPOINT	
MEAN HEADSPACE	35.0 mL (1.18 FL.OZ.) WITHOUT CORK 4.7%
MAXIMUM HEADSPACE	42.4 mL (1.43 FL.OZ.) " 5.7%
MINIMUM HEADSPACE	27.6 mL (0.93 FL.OZ.) " 3.7%

APPROVAL	REFERENCE

DRN BY	DATE	ITEM NO.	DWG. NO.	REV.
L.D.F	4/6/2006		LQ-06-0400	B

LET	REVISION	DATE
B	FILLPOINTS CORRECTED AND FINALIZED.	9/3/2015
A	BEARING STYLE KNURL WAS RIB STYLE	5/7/2008